



INDUSTRIES, INC.

13-16 133 PLACE
COLLEGE POINT, NY 11356

TEL: (718)747-0237
FAX: (718)747-0726

THE PLANS AND DRAWINGS CONTAINED HEREIN ARE PROPRIETARY AND MAY NOT BE COPIED OR REPRODUCED MECHANICALLY, ELECTRONICALLY OR BY ANY MEANS WITHOUT WRITTEN PERMISSION FROM AFC INDUSTRIES, INC.



ISOMETRIC VIEW

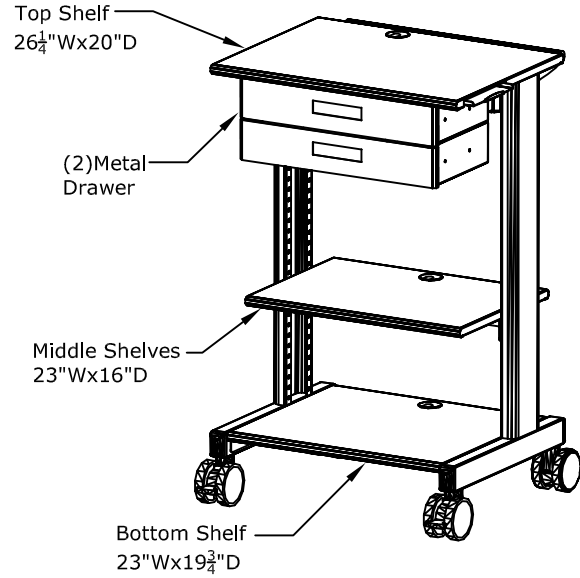
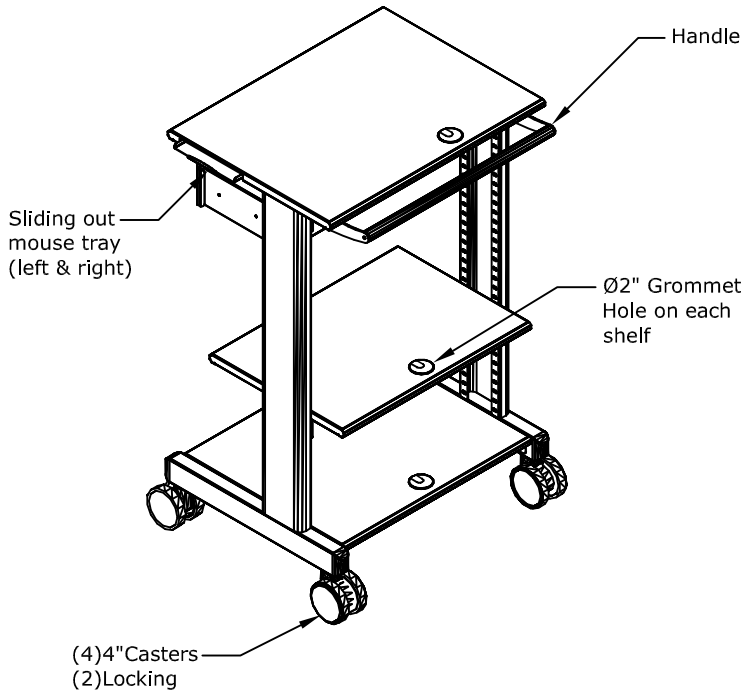

FRONT VIEW

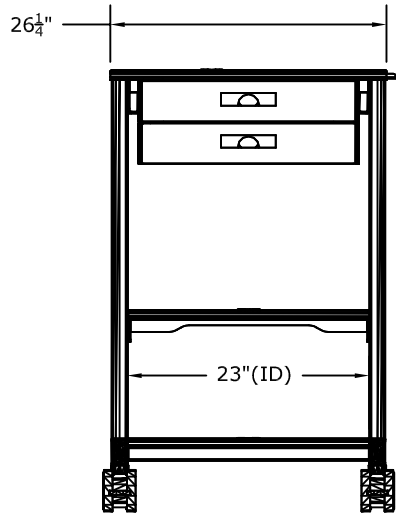

SIDE VIEW

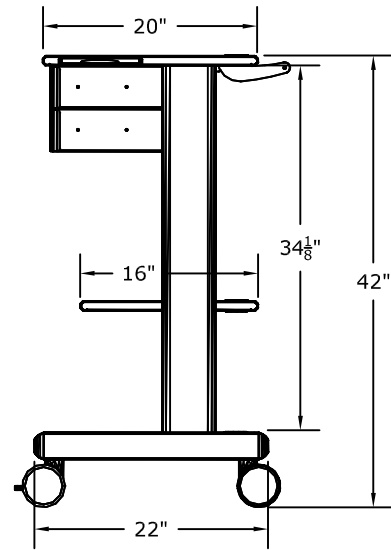

NOTE :	DRAWN BY : PR/YN	DATE: 11/08/12	DESCRIPTION :		
	A P P R O V E D		LAB CART		
TOLERANCES UNLESS OTHERWISE SPECIFIED FRACTIONAL ±1/64 2 PLC. DEC. ±.01 3 PLC. DEC. ±.001 ANGULAR ±.5° FINISH $\sqrt{32}$	ENG :		USED ON :		
	MFG :		PATH : L/Final Assmby/C&R/Lab Cart		
	QA :		NUMBER :	LAYER :	REV: SIZE
	SCALE: N.T.S.	SHEET : 1 OF 1	LB200-101-12		A