

TOP VIEW

SCALE: 1-1/2" = 1' - 0"

(2) AFCZ5-88 VESA 75/100
Compliant Monitor Holder

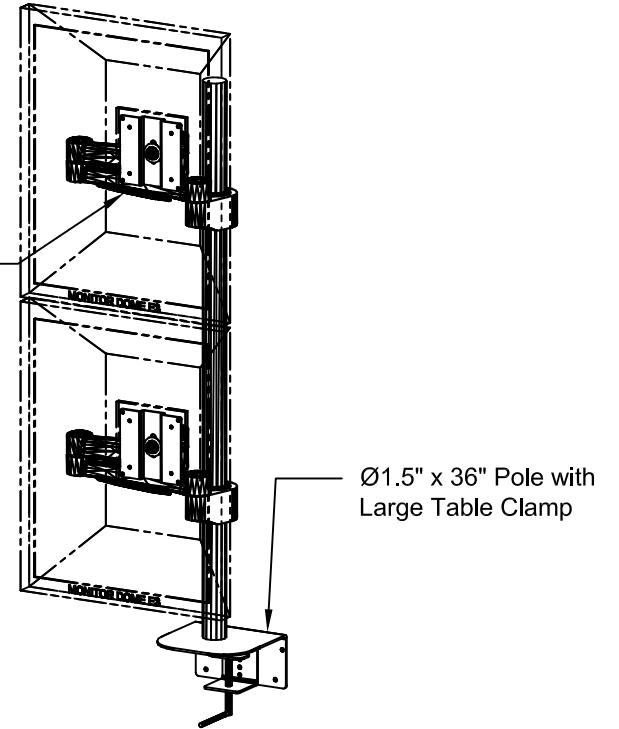

ISOMETRIC VIEW

NOTES : Shown Images of DOME E3 Monitors	MATERIAL :	DRAWN BY : BD	DATE: 12/18/13	DESCRIPTION :
	.	A P P R O V E D		Pole with 2 Vertical Monitors
	TOLERANCES UNLESS OTHERWISE SPECIFIED	ENG :		USED ON :
	FRACTIONAL ±1/64	MFG :		.
	2 PLC. DEC. ±.01	QA :		PATH :
	3 PLC. DEC. ±.001	SCALE: ~1" = 1' - 0"	SHEET: 1 OF 1	PDF NAME:
	ANGULAR ±.001			REV: SIZE
	FINISH			AFCZ588-02V-DMC-36P
	±.5° 32/			A