

VIEW A

Switch for vertical cassette holder adjustment

Spring loaded knob that holds cassette holder either in vertical or in horizontal position

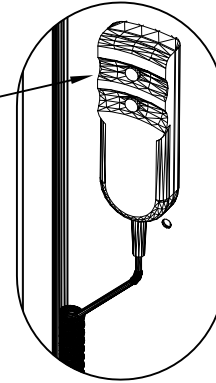

VIEW B

Upper height adjustable grid holder that slides on frame and locks by (1) screw

Slider that moves vertically by electric driving mechanism a rotating unit with sitting on it a cassette holder

Upper height adjustable cassette holder that slides on frame and locks by (2) screw with knob

Rotating unit

Lower height adjustable cassette & grid holder that slides on frame and locks by (2) knobs

Frame of cassette holder attached to revolving unit with middle and (2) side aluminum profile guides

Main body - vertical structure that joins all parts together and includes main vertical guide, main driving screw and electrical driving mechanism

Place for UPS (Uninterruptible Power Supply) or other equipment

(4) Ø4" double casters. Front two are lockable.

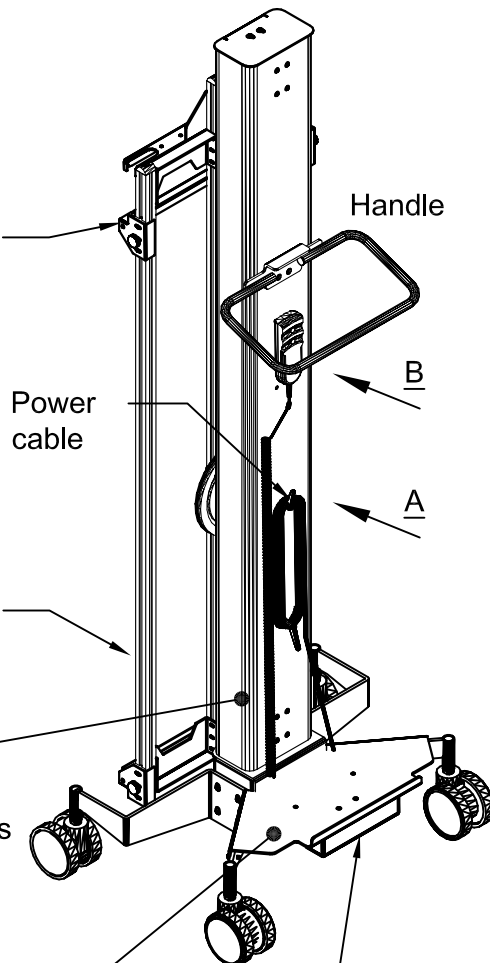

Handle

Power cable

Control Box

ISOMETRIC FRONT VIEW

ISOMETRIC BACK VIEW

MATERIAL :	DRAWN BY: BD	DATE: 01/06/10	DESCRIPTION :
	APPROVED		MACH-ONE (Electric) Manual
TOLERANCES UNLESS OTHERWISE SPECIFIED FRACTIONAL ±1/64 2 PLC. DEC. ±.01 3PLC. DEC. ±.001 ANGULAR ±.5° FINISH	ENG :		USED ON :
	MFG :		PATH :
	QA :		NUMBER :
	NOT TO SCALE	SHEET: 1 OF 3	MACH-ONE-EI-M-01