

(4) AFCZ5-44 VESA 75/100
Compliant Monitor Holder on
Slider+(1)3255 on Slider and
track

TOP VIEW
SCALE: 3/4" = 1' - 0"

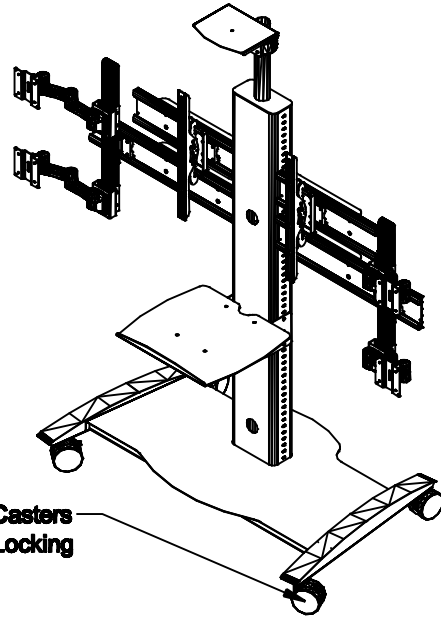

(4) Ø4" Casters
(2) Locking

ISOMETRIC VIEWS

FRONT VIEW

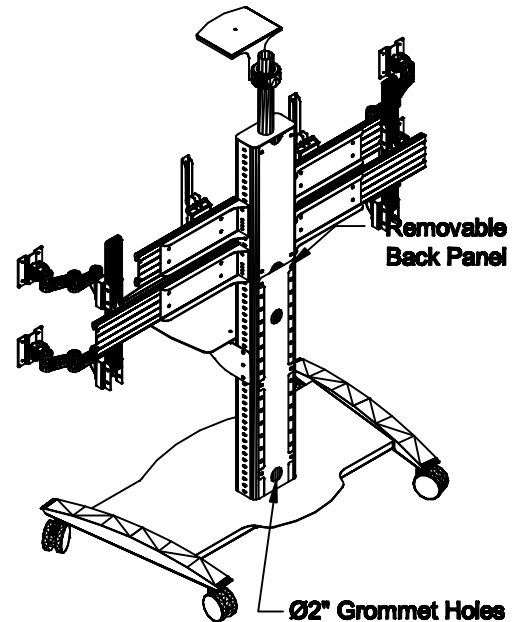
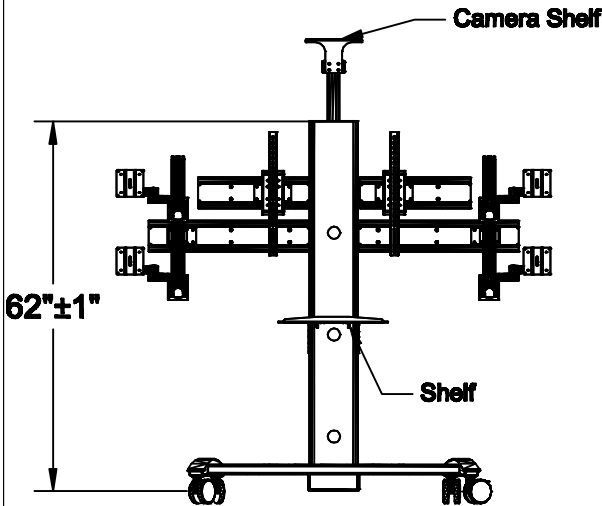

| | | | |
|---|-----------------------|---------------|---|
| NOTE. | DRAWN BY: GM | DATE: 9/13/16 | DESCRIPTION : |
| | APPROVED | | Plasma Cart |
| <p>TOLERANCES UNLESS OTHERWISE SPECIFIED</p> <p>FRACTIONAL ±1/64</p> <p>2 PLG. DEC. ±.01</p> <p>3PLG. DEC. ±.001</p> <p>ANGULAR</p> <p>FINISH</p> | ENG: | | SKU NUMBER : |
| | MFG: | | 771830 |
| | QA: | | PATH : |
| | SCALE: 1/2" = 1' - 0" | SHEET: 1 OF 1 | \Fin.Assy\CartsSystem\PlasmaCart\XLCD300\ |
| | | | NUMBER : |
| | | | XLCD300_07_REV 02 |
| | | | SIZE |
| | | | A4 |